



www.sumiteknatraj.com

Global Presence

Global Presence



Sumitek Natraj Machinery Private Limited

Plot No. 564, Kathwada G.I.D.C., Opp. Road.10, Nr. Tribhuvan Estate Gate, Phase-2, Kathwada, Tal-Daskroi, Ahmedabad-382430. Gujarat, India.

Website : www.sumiteknatraj.com
: www.natrajind.com

Vendor INQ : Mo.: +91- 95128 20014
Marketing : Mo.: +91- 93138 06754, 95128 20013, 75676 16655

E-mail : sales@sumiteknatraj.com | marketing@sumiteknatraj.com
: support@sumiteknatraj.com | export@sumiteknatraj.com

Service Network : Gujarat, Maharashtra, Delhi, Karnataka, Tamilnadu, Telangana, Madhya Pradesh



For Website



For PDF Brochure

www.xadax.in | 9/23

www.sumiteknatraj.com



servo GREEN

Toggle Injection Moulding Machines



80 TO 600 TON

We believe that *Excellence* is a journey not a *Destination*

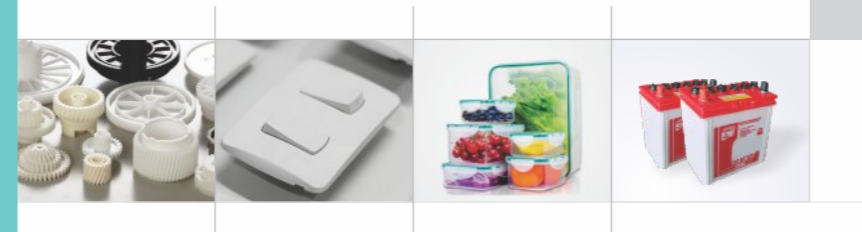



Shape Business Through Moulding

ABOUT US

SUMITEK NATRAJ MACHINERY PRIVATE LIMITED is leading manufacturer of plastic injection moulding machines established in the year 1976, we have achieved great feats in the field. We are known for our dynamism towards the technological advancements and for the outstanding customer service in the industry. In view of environmental concerns all over world, we continue to use latest technology to ensure our products remain energy efficient.

We have modular product range of various injection moulding machines consisting of GT SERVO, SERVO GREEN, ACTIVE, PETLINE, PVC STREAM SERVO, CPVC STREAM SERVO, ACCUFAST, SPAR, WAVE ranging from 800 kn to 6000 kn clamping force, with moulder injection Units 270 to 4800 to meet customer's specific needs.

With expertise of more than 40 years in manufacturing of PIMMS, we have always been preachers and executors of MAKE IN INDIA. The SUMITEK NATRAJ brand is synonymous with great RELIABILITY, high PRECISION and QUALITY having applications for automotive engineering, electrical parts, house hold, pharmaceuticals, packaging and beverage industries etc.

Recognized as one of the world's most trusted and innovative manufacturer of plastic injection moulding machines (PIMMs) by providing our customers highest quality products that combine performance and advanced technology with value pricing.

VISION

Continue to offer quality products to meet customer's needs beyond their expectations.



OUR FOCUS

- *Customer's Satisfaction
- *Quality Products



SERVO GREEN

80 TO 600 TON

SERIES MACHINES ARE SUITABLE FOR A WIDE VARIETY OF APPLICATIONS

AUTOMOBILE PRODUCTS



INDUSTRIAL MOULDING PRODUCTS



HOUSEHOLD & FURNITURE PRODUCTS



WHITE GOODS & TOYS



ELECTRIC & PHARMA PRODUCTS



HDPE PIPE FITTINGS & PPR FITTINGS



CRATES & CAPS



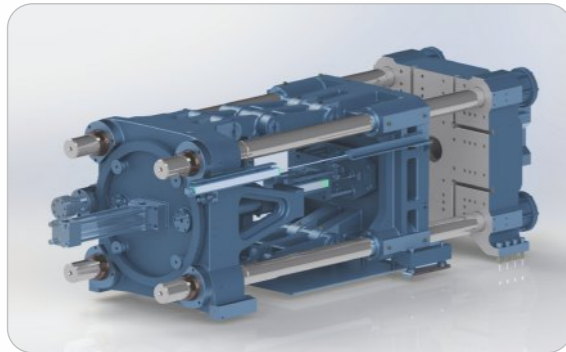

CLAMPING UNIT

- Heavy Duty 5-point Double Toggle Mechanism With Large Mould Opening Stroke.
- High Stiffness Platen Design With Large Mould Mounting Area.
- Platen Casting Design With Finite Element Analysis For Maximum Rigidity.
- Mould Platen With T-slots (140 Ton & Above).
- Long Life By Providing Oil Less Bushing With Graphite Impregnated For Toggle Mechanism.
- Platens With Euromap Standard.
- Long Moving Platen Guide Increases Mould Life.



NUT GEAR

- High Wear Resistant & High Strength Bronze Gear Nut (tiebar Nut) That Gives Rigid & Positive Clamping Force.
- Friction Free Easy Moving Mould Height.

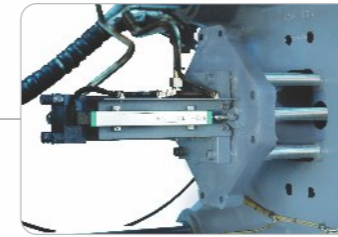

EJECTOR

- Smooth & Fast Ejection.
- Multiple Ejection Point & Evenly Distributed Ejection Force.
- Euromap Ejection Point.
- Easy Accessibility.

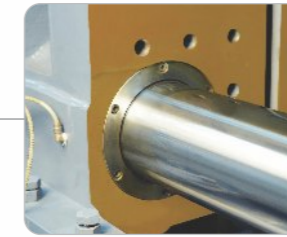

WIPER SEAL

- Keep Lubrication between Platen Hole & Tiebar For Smooth Movement.
- Dust Free Moving Platen Movement Gives Better Tiebar Life

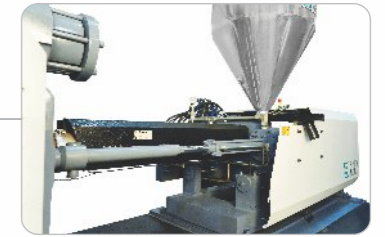

INJECTION UNIT

- High Torque Hydraulic Motor For Better Plasticization.
- Longer Life Of Mould With Dual Nozzle Cylinder Design
- Provision For Multiple Screw Change By Changing Spline Bush Only.
- Low Noise Hydraulic Motor.
- Carriage Loaded Injection to Prevent Material Leakage

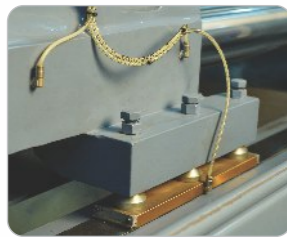

SKATE PAD

- High Wear Resistant Skate-pad For Heavy Mould Loading That Reduces Platen Deflection and Enhances Tiebar Life.
- High Wear Resistant Carbon Steel Strip.

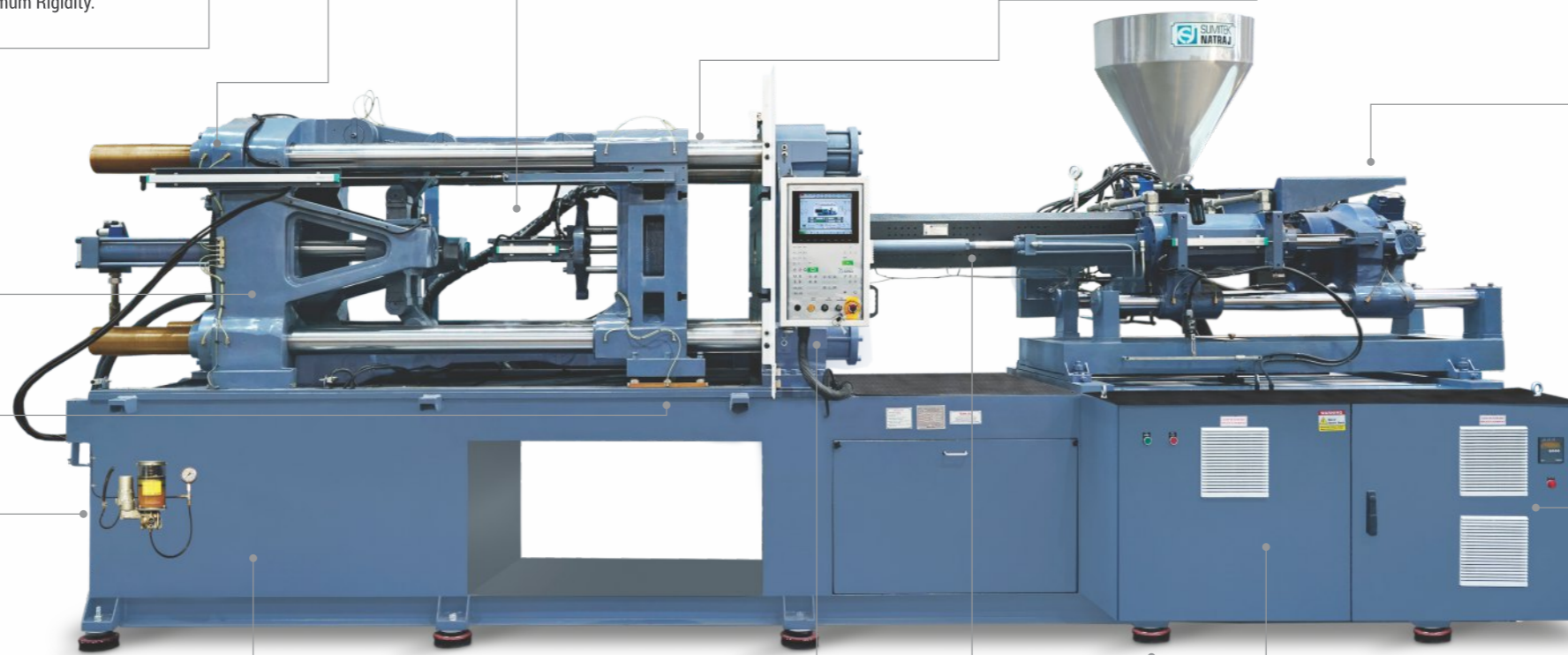

ELECTRICAL PANEL

- Energy Meter.
- High Quality Electrical Components And Excellent Circuit Hardware Design.
- Stable And Reliable Control System With A Stronger Anti-interference Function.
- Ease In Maintenance.
- Over Voltage, Under Voltage Phase Loss And Phase Sequence Protection.
- Separate And Spacious Power & Control Wiring.
- 230 VAC Components Safe By Isolation Transformer.
- Ensured Panel Safety with IP-54 Protection.



AUTOMATIC GREASE LUBRICATION

- High Pressure Grease Lubrication System Provides Positive Lubrication.
- Ensures Continuous And Optimum Lubrication To Reduce Friction & Longer Toggle Life.



HMI

- 8.0/10.4 Inch , TFT Colour Display.
- Precise Mould Safety.
- High Speed Microprocessor Controller.
- Self Diagnostics & Fault Finding Capacity.
- Graphical Presentation Of Important Functions.
- Automatic Calibration Of Sensors And Valves.
- PDP & SPC Function.
- Multiple User Passwords.
- Quality Data Logging.
- Unlimited Mould Data Storage Through USB
- USB Connection For Printer, Modem, USB Stick etc.

ANTI VIBRATING PAD

- Minimum Vibrations.
- Precise & Fast Leveling.
- No Civil Foundation Required.



SCREW & BARREL

- Gas Nitrided Injection Screw & Barrel For The Ultimate In Wear Resistance.
- Process Ability At Lower Melting Temperature.
- Excellent Homogeneous Melting.
- Special Screw Design.
- Improved Product Quality.
- Better Plastication Rate.



SERVO TECHNOLOGY

- Outstanding Power Saver.
- Precise And Fast Response.
- Outstanding Consistency And Repeatability.
- Low Noise Level.
- Lower Oil Heat Generation.
- Faster Response Towards Hydraulic System.
- Enhanced Oil & Hydraulic Seal's Life.
- Less Cooling Water Consumption.

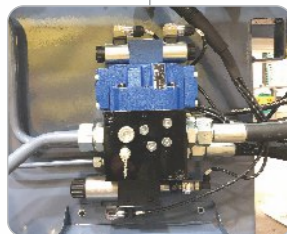

ENERGY EFFICIENT HYDRAULIC

- Return Line Filter With Clogging Sensor.
- High Efficiency & Fast Response Hydraulic Valve With Applicable Pipe Size Selection Reduces Oil Heat & Saves Power.
- Hydraulic Directional Valve With On /off Indicator Connector.

Model	UNIT	080 Ton									100 Ton									140 Ton									180 Ton									200 Ton								
		270			270			410			270			410			590			410			590			1050			410			590			1050											
		AA	A	B	AA	A	B	AA	A	B	AA	A	B	AA	A	B	AA	A	B	AA	A	B	AA	A	B	AA	A	B	AA	A	B	AA	A	B	AA	A	B	AA	A	B						
INJECTION CAPACITY MAX. (GPPS)	gm	130	165	200	130	165	200	190	240	300	130	165	200	190	240	300	260	330	410	190	240	300	260	330	410	445	540	640	190	240	300	260	330	410	445	540	640									
INJECTION PRESSURE	bar	2279	1800	1458	2279	1800	1458	2351	1904	1505	2279	1800	1458	2351	1904	1505	2476	1957	1585	2351	1904	1505	2476	1957	1585	2126	1757	1476	2351	1904	1505	2476	1957	1585	2126	1757	1476									
INJECTION RATE	cc/sec	93	117	145	93	117	145	90	110	141	119	150	186	115	142	180	137	173	214	144	178	225	137	173	214	200	241	287	180	223	282	171	217	268	200	241	287									
INJECTION SCREW STROKE	mm	170	170	170	170	170	170	200	200	200	170	170	170	200	200	200	220	220	220	200	200	220	220	220	220	240	240	240	200	200	200	220	220	220	240	240	240									
SCREW DIAMETER	mm	32	36	40	32	36	40	36	40	45	32	36	40	36	40	45	40	45	50	36	40	45	40	45	50	50	55	60	36	40	45	40	45	50	50	55	60									
SCREW L / D RATIO	-	24.8	22	19.8	24.8	22	19.8	24.5	22	19.6	24.8	22	19.8	24.5	22	19.6	24.8	22	19.8	24.5	22	19.6	24.8	22	19.8	23	21	19.2	24.5	22	19.6	24.8	22	19.8	23	21	19.2									
SCREW SPEED	rpm	300	300	300	300	300	300	200	200	200	300	300	300	300	300	300	240	240	240	300	300	300	240	240	240	170	170	170	300	300	300	240	240	240	200	200	200									
NO. OF HEATING ZONES (BARREL+NOZZLE)	-	3 + 1N			3 + 1N			3 + 1N			3 + 1N			3 + 1N			4 + 1N			3 + 1N			4 + 1N			4 + 1N			3 + 1N			4 + 1N			4 + 1N											
TOTAL HEAT CAPACITY	kw	10.2			10.2			11.8			10.2			11.8			14.1			11.8			14.1			18.1			11.8			14.1			18.1											
CLAMP UNIT																																														
CLAMP FORCE	ton	80						100						140						180						200																				
CLAMP STROKE	mm	300						320						360						450						475																				
MAXIMUM DAYLIGHT	mm	650						720						830						1000						1075																				
MINIMUM MOULD HEIGHT	mm	125						150						150						200						200																				
MAXIMUM MOULD HEIGHT	mm	350						400						470						550						600																				
PLATEN SIZE (H x V)	mm	535 x 550						590 x 605						670 x 670						755 x 755						823 x 765																				
DISTANCE BETWEEN TIEBAR (H x V)	mm	360 x 360						400 x 400						445 x 445						540 x 505						570 x 500																				
EJECTOR STROKE	mm	100						100						120						140						160																				
EJECTOR FORCE	ton	3.3						5.3						5.3						5.3						7.5																				
MOULD WEIGHT CAPACITY	kg	400						650						1000						1300						1500																				
GENERAL																																														
SERVO DRIVE	kw	9.5						9.5						11						13						18						22														
TOTAL OIL TANK CAPACITY	ltr	210						260						260						315						315						400														
CONNECTED LOAD	kw	19.7						19.7						22.8						23.2						29.8						36.1														
MACHINE DIMENSIONS (L x W x H)	m	4 x 1.5 x 2						4.5 x 1.5 x 2						4.5 x 1.5 x 2						5 x 1.6 x 2.1						5 x 1.6 x 2.1						5.2 x 1.6 x 2.1														
MACHINE WEIGHT (Approx.)	ton	3.6						4.2						4.4						5.2						5.4						5.9														

Model	UNIT	280 Ton									360 Ton									480 Ton									600 Ton											
		1050			1430			1860			1430			1860			2090			2090			3220			3220			4800											
		AA	A	B	A	B	C	A	B	C	A	B	C	A	B	C	A	B	C	A	B	C	A	B	C	A	B	C	A	B	C									
INJECTION CAPACITY MAX. (GPPS)	gm	445	540	640	740	870	1000	1000	1160	1335	740	870	1000	1000	1160	1335	1310	1500	1710	1310	1500	1710	1900	2400	2965	1900	2400	2965	3710	4490	5340									
INJECTION PRESSURE	bar	2126	1757	1476	1750	1491	1286	1665	1436	1251	1750	1491	1286	1665	1436	1251	1615	1407	1236	1615	1407	1236	1695	1339	1085	1695	1339	1085	1940	1600	1350									
INJECTION RATE	cc/sec	200	241	287	305	358	416	321	372	427	305	358	416	408	473	543	525	685	870	525	685	870	630	800	985	630	800	985	905	1095	1305									
INJECTION SCREW STROKE	mm	240	240	240	280	280	280	320	320	320	280	280	280	320	320	320	360	360	360	360	360	360	400	400	400	400	400	400	500	500	500									
SCREW DIAMETER	mm	50	55	60	60	65	70	65	70	75	60	65	70	65	70	75	70	75	80	70	75	80	80	90	100	80	90	100	100	110	120									
SCREW L / D RATIO	-	23	21	19.2	22	20.3	21.5	22	20.5	22	22	20.3	21.5	22	20.5	22	22	20.5	22	22	20.5	22	24	21.5	22	24	21.5	22	23	22	22									
SCREW SPEED	rpm	200	200	200	170	170	170	150	150	150	200	200	200	170	170	170	150	150	150	170	170	170	150	150	150	150	150	150	140	140	140									
NO. OF HEATING ZONES (BARREL+NOZZLE)	-	4 + 1N			4 + 1N			4 + 1N			4 + 1N			4 + 1N			4 + 1N			4 + 1N			4 + 1N			4 + 1N			4 + 1N											
TOTAL HEAT CAPACITY	kw	18.1			22.5			25.7			27			31.2			22.5			25.7			32			36.6			32			36.6			40			45.8		
CLAMP UNIT																																								
CLAMP FORCE	ton	280									360									480									600											
CLAMP STROKE	mm	580									680									830									950											
MAXIMUM DAYLIGHT	mm	1380									1510									1725									2020											
MINIMUM MOULD HEIGHT	mm	200									200									300									400											
MAXIMUM MOULD HEIGHT	mm	800									830									900									1070											
PLATEN SIZE (H x V)	mm	900 x 895									1035 x 1035									1210 x 1180									1350 x 1355											
DISTANCE BETWEEN TIE ROD (H x V)	mm	650 x 600									720 x 680									830 x 770									980 x 880											
EJECTOR STROKE	mm	160									200									205									225											
EJECTOR FORCE	ton	8.5									8.5									10.8									13.3											
MOULD WEIGHT CAPACITY	kg	2700									4000									5500									7000											
GENERAL																																								
SERVO DRIVE	kw	25			30			35			30			35			40			40			50			50			60											
TOTAL OIL TANK CAPACITY	ltr	510			510			660			660			660			850			850			850			850			950											
CONNECTED LOAD	kw	43.1			52.5			55.7			62			66.2			72			76.6			72			76.6			90			95.8								
MACHINE DIMENSIONS (L x W x H)	m	6.5 x 1.9 x 2.4			6.5 x 1.9 x 2.4			6.8 x 1.9 x 2.4			7 x 2.1 x 2.5			7 x 2.1 x 2.5			7.5 x 2.3 x 2.7			7.5 x 2.3 x 2.7			8.5 x 2.3 x 2.6			9 x 2.3 x 2.6			8.5 x 2.3 x 2.6			9.5 x 2.3 x 2.6								
MACHINE WEIGHT (Approx.)	ton	11.3			12			12.4			14.4			15			15.7			22.2			23.2			29			30.5											

• Injection unit change is possible as per requirements. • Actual figures may change depending on your final machine configuration.

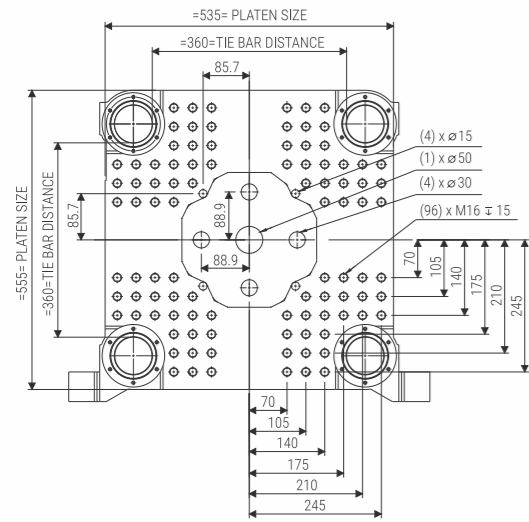

SERVO GREEN 80 Moving Plate

Stationary Platen : Locating Ring Ø125 (-0.05 TO -0.10)

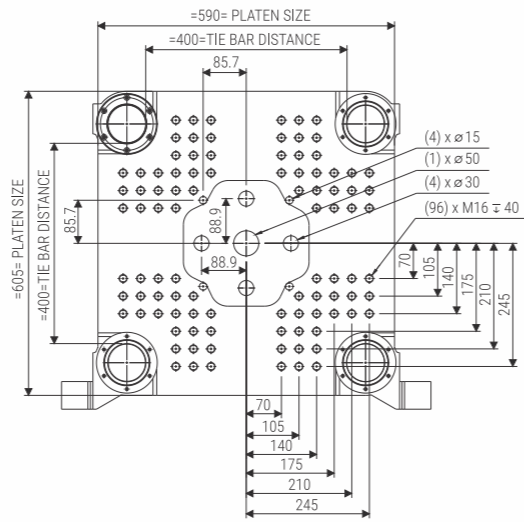

SERVO GREEN 100 Moving Plate

Stationary Platen : Locating Ring Ø125 (-0.05 TO -0.10)

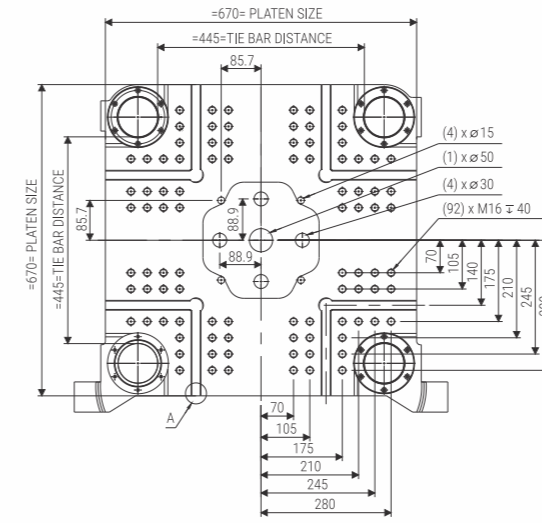

SERVO GREEN 140 Moving Plate

Stationary Platen : Locating Ring Ø125 (-0.05 TO -0.10)

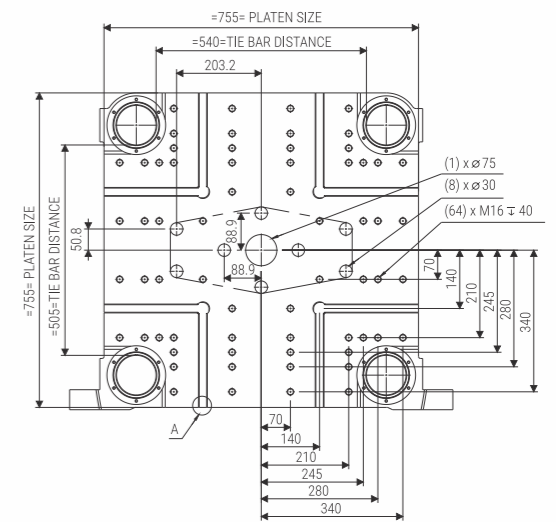

SERVO GREEN 180 Moving Plate

Stationary Platen : Locating Ring Ø125 (-0.05 TO -0.10)

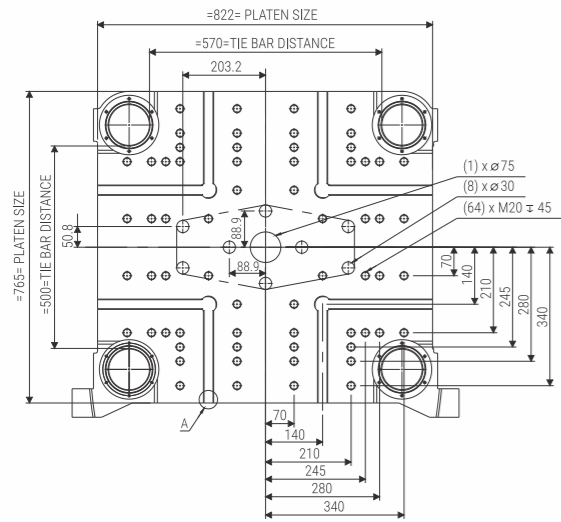

SERVO GREEN 200 Moving Plate

Stationary Platen : Locating Ring Ø160 (-0.05 TO -0.10)

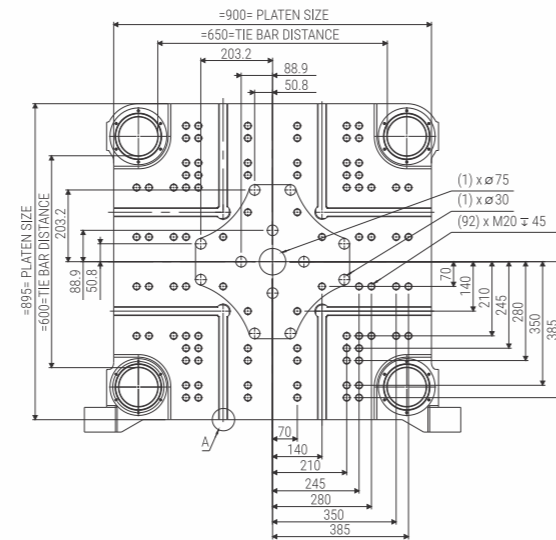

SERVO GREEN 280 Moving Plate

Stationary Platen : Locating Ring Ø160 (-0.05 TO -0.10)

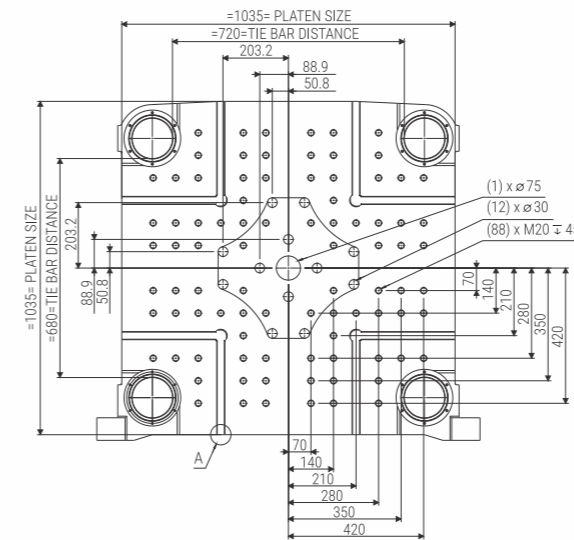

SERVO GREEN 360 Moving Plate

Stationary Platen : Locating Ring Ø160 (-0.05 TO -0.10)

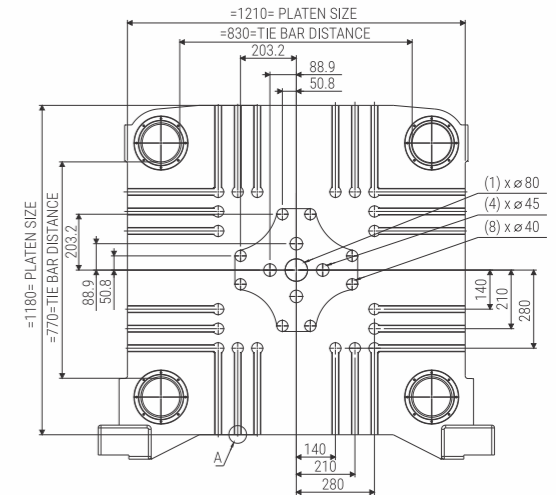

SERVO GREEN 480 Moving Plate

Stationary Platen : Locating Ring Ø200 (-0.05 TO -0.10)

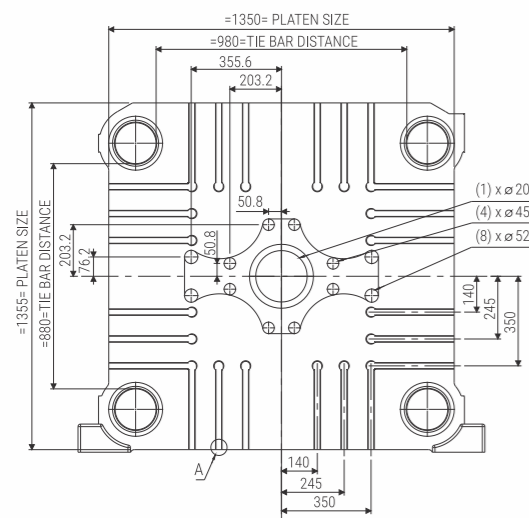

SERVO GREEN 600 Moving Plate

Stationary Platen : Locating Ring Ø250 (-0.05 TO -0.10)

T-SLOT DETAIL OF STATIONARY PLATEN & MOVING PLATEN

MACHINE	T-SOLT			
	A	B	C	D
80 TON	-	-	-	-
100 TON	-	-	-	-
140 TON	18	32	14	36
170 TON	18	32	14	36
200 TON	22	40	18	45
280 TON	22	40	18	45
360 TON	22	40	18	45
480 TON	22	40	18	45
600 TON	22	40	18	45

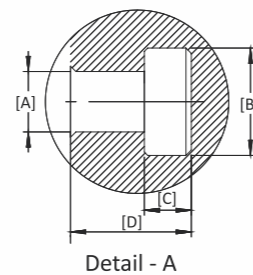

NOTE : ALL DIMENSIONS ARE IN MM.
T-SLOT & THREAD DIMENSIONS ARE AS PER EURO MAP STANDARD.
EJECT. CENTER DIST. ARE TYPICAL IN FOUR QUADRANTS

PLASTIC MATERIALS CHARACTERISTICS

MATERIAL	DENSITY gm/cc	PROCESSING TEMPERATURE (C°)	CLARITY T/O/C	kg/cm2 TENSILE STRENGTH AT YEILD	ELONGATION AT BREAK %	SOFTENING TEMPRATURE VICAT 0° C	HEAT DEFLECTION 0° C AT 66 PSI
LDPE	0.92	160-210	Translucent	95	200	85	50
LLDPE	0.92	180-260	Translucent	100	100	80	45
HDPE	0.96	190-280	T-O	250	500	126	75
PP Copolymer	0.90	190-300	T-C	290	500	150	90
PP Homopolymer	0.90	190-300	Translucent	310	200	152	96
PS (GPPS)	1.05	180-220	Clear	420	5	102	85
HIPS	1.05	180-220	T-O	275	45	88	83
ABS	1.05	210-270	Opaque	440	20	95	86
SAN	1.04	220-270	Clear	650	4	107	95
Polycarbonate (PC)	1.2	260-310	Clear	680	150	150	144
Nylon-6	1.13	240-270	T-O	740	40	215	165
Nylon-66	1.13	270-300	T-O	1240	300	245	238
RPVC	1.45	150-210	Clear	440	20	-	76
Acrylics	1.19	200-260	Clear	700	3	89	90
PBT	1.31	220-260	Opaque	530	300	172	155
Polyurethane	1.20	185-240	Clear	520	510	116	-
Acetal	1.41	180-240	Opaque	700	55	-	172
TPE	1.2	180-240	Opaque	310	375	195	111
PET	1.38	260-310	Clear	880	70	110	85

**CLAMPING UNIT
IN RESPECT OF ALL MODELS.**

Heavy duty 5-point double toggle mechanism with large mould opening stroke.
High stiffness platen design with large mould mounting area.
High wear resistance & high strength gear nut (tiebar nut) gives rigid & positive clamping force.
Five stage mould close / open speed (slow-fast-slow) & pressure.
Multi stage digital speed and pressure setting to operate the mould.
Computer aided design toggle mechanism gives optimal mould closing and opening speed profits.
Ramping adjustment for accurate position.
Linear transducer for accurate clamp position.
Mould protection with repeat again option.
Travel time display for close & open for producing any item while operations.
Auto-mould height adjustment with hydraulic motor.
Hard-chrome plated high-tensile steel tie-bars with stress relieve design.
Auto-lubrication based on shot adjustment (as standard features).
Hydraulic ejector with multiple selection. (continuous, shake, hold etc.)
Linear transducer on ejector cylinder.
Shaking ejector for multi-cavity mould.
Less vibrations & jerks due to ramp adjustment.
Large mould mounting area for producing large articles especially useful for pet preform, pipe fittings etc.
Platen casting design with finite element analysis for maximum rigidity.
Mould platen with t-slots (140 Tons & above).
Hydraulic & electrical safety interlocks during moving platen movements for moulds & operator safety.
Separate pressure & speed setting for mould set-up.
All casting passed through strict ultrasonic test and tensile testing process.
High wear resistant skate-pad for heavy mould loading.
Long life by providing oil less bushing, with graphite impregnated for toggle mechanism.
Transparent vision on both safety doors.
Trouble free precise clamping force for long period through heavy-duty toggle design.
Extra life to toggle mechanism with top fixed cover which keeps clamping unit dust free.

HYDRAULIC SYSTEM

Energy efficient servo hydraulic system.
Digital oil temperature gauge.
Oil level gauge (low & high).
Direct reading hydraulic pressure.
Contamination free oil tank with Air breather.
Compact, easily accessible injection and clamping valves to minimize the heat generation.
Return line filter as standard accessories.
Alarm / shut down for return filter clogging.
Alarm / shut down for low oil level. (hydraulic tank)
Alarm / shut down for low lubrication oil level.
Provides high safety as main motor shuts down on opening rear gate.
Hydraulic directional valve on/off indicator connector.
Inline 10 Micron Filtration unit for Oil Filling Port.

SAFETY FEATURES IN RESPECT OF ALL MODELS.

Hydraulic safety on both front & rear door. | Electric mould safety. | Magnetic grills in hopper. | Provision for M.C.C.B.
Over load circuit breaker. | Under voltage-over voltage protection. | Reverse phase, single phase protection.
Providing hooks of commensurate size for risk free lifting of machine.

**CONTROL SYSTEM
IN RESPECT OF ALL MODELS.**

Energy meter.
Multi password facility for operators.
M.C.C.B. Operating Mechanism.
SMPS - Switched Mode Power Supply gives Linear power supply.
Digital setting timers.
M.C.B. for each heating zone.
PID temp controller for accurate control.
Dedicated microprocessor control system with led input / output indicator for simplified checking
Digital display timer.
Digital display shot counter.
MPCB for motor protection.
Pressure & flow for each function control by Microprocessor.
Linear scale for injection, clamping & ejector cylinder.
Value change record page.
Alarm history page.
Printer interface with USB port.
Production / hour in vertical-bar for year.
In case of short circuit I/O replaceable on board.
Easy export / import of mould & machine data.
Hold button for on screen help (related to controller).
Injection cool prevent time stable.
Panel cabinet high temperature shut-down.
Power ON time.
Extra electric power supply socket for single phase & three phase.
Hourly energy consumption statics page (Product cost calculator)
Remote diagnosis by connecting with local PC via Ethernet port for any no. of machine.

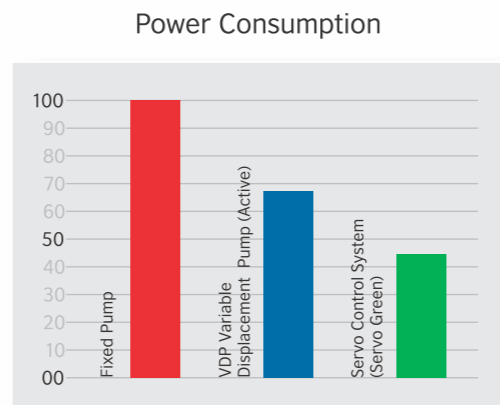

**INJECTION UNIT
IN RESPECT OF ALL MODELS.**

Gas nitrided hardened screw and barrel, for wear resistance and long life.
Screw for homogenous plasticizing with maddock design.
Screw back pressure with pressure gauge provision.
High torque hydraulic motor for better plasticization.
5-stage injection speed pressure & position control.
3-stage injection holding speed pressure & position control.
Hopper sliding arrangement for material removal.
Electric shot counter.
Cold slug Ejection by time.
Intrusion moulding program.
Selection of injection time & position both.
Screw tachometer (Digital RPM).
Pre-suck back function and after plasticizing suck back.
Heater failure & thermocouple failure detector.
High / low temperature alarm. (suitable low-high limit)
Auto heat start-up.
Longer life of mould with Twin Cylinder Design & Dual nozzle centering alignment device.
Linear potentiometer for injection / plasticizing.
Auto purging facility.
Ceramic bands heaters for instant heating.
Barrel heater safety cover.
Nozzle contact force confirmation with use of pressure switch.
Temperature Sensor at feed throat to ensure continuous production.
S.S. Water Manifold.

MACHINE VERSION LIST

FEATURE DESCRIPTION	V+	V++	PRO	PRO+	PRO++
CP-31/T-ECO PLC	✓	✓	✗	✗	✗
CP-33/T-Expandable PLC MODEL - 1075-0610-00	✗	✗	✓	✓	✓
En201 Safety for Clamping unit	✓	✓	✓	✓	✓
Digital Back Pressure	✗	✓	✓	✓	✓
High Speed Injection Unit	✗	✓	✓	✓	✓
High Speed Clamping Unit	✗	✗	✓	✓	✓
LM Guideways for Injection Unit	✗	✗	✓	✓	✓
LM Guideways for Clamping Unit	✗	✗	✗	✓	✓
2 Zone Hot runner output	✗	✗	✓	✗	✗
3 Zone Hot runner output	✗	✗	✗	✓	✓
Robot Interface Euromap 67	✗	✗	✓	✓	✓
Energy Meter	✗	✗	✗	✓	✓
Clamp Proportional valve for accurate mold positional accuracy	✗	✗	✗	✓	✓
Injection Proportional valve for accurate Injection Shot accuracy	✗	✗	✗	✗	✓
Water flow control valve on Heat exchanger	✗	✗	✗	✓	✓

• Photography may show attachments or accessories, which may not be part of the standard scope of supply.
• Due to continuous improvements with up-gradation of technology specification & components are subject to change without notice.