



www.sumiteknatraj.com

Global Presence

Global Presence



Sumitek Natraj Machinery Private Limited

Plot No. 564, Kathwada G.I.D.C., Opp. Road.10, Nr. Tribhuvan Estate Gate, Phase-2, Kathwada, Tal-Daskroi, Ahmedabad-382430. Gujarat, India.

Website : www.sumiteknatraj.com
: www.natrajind.com

Vendor INQ : Mo.: +91- 95128 20014
Marketing : Mo.: +91- 93138 06754, 95128 20013, 75676 16655

E-mail : sales@sumiteknatraj.com | marketing@sumiteknatraj.com
: support@sumiteknatraj.com | export@sumiteknatraj.com

Service Network : Gujarat, Maharashtra, Delhi, Karnataka, Tamilnadu, Telangana, Madhya Pradesh



For Website



For PDF Brochure

www.xadax.in | 1/23

www.sumiteknatraj.com



Petline

Toggle Injection Moulding Machines

SERVO / VDP

80 TO 600 TON

We believe that *Excellence* is a journey not a *Destination*





Shape Business Through Moulding

ABOUT US

SUMITEK NATRAJ MACHINERY PRIVATE LIMITED is Leading manufacturer of Plastic Injection Moulding Machines Established in the year 1976, we have achieved great feats in the field. We are known for our dynamism towards the technological advancements and for the outstanding customer service in the industry. In view of environmental concerns all over world, we continue to use latest technology to ensure our products remain energy efficient.

We have modular product range of various injection moulding machines consisting of **ACTIVE, SERVO GREEN, PETLINE, PVC STREAM SERVO, CPVC STREAM SERVO, ACCUFAST, SPAR, WAVE** ranging from 800 kn to 6000 kn clamping force, with modular injection Units 270 to 4800 to meet customer's specific needs.

With expertise of more than 40 years in manufacturing of PIMMS, we have always been preachers and executors of MAKE IN INDIA. The SUMITEK NATRAJ brand is synonymous with great RELIABILITY, high PRECISION and QUALITY having applications for automotive engineering, electrical parts, house hold, pharmaceuticals, packaging and beverage industries etc.

Recognized as one of the world's most trusted and innovative manufacturer of plastic injection moulding machines (PIMMs) by providing our customers highest quality products that combine performance and advanced technology with value pricing.

VISION

Continue to offer quality products to meet customer's needs beyond their expectations.



OUR FOCUS

- *Customer's Satisfaction
- *Quality Products



Petline

SERVO / VDP 80 TO 600 TON

SERIES MACHINES ARE SUITABLE FOR A WIDE VARIETY OF APPLICATIONS

APPLICATIONS

MINERALS & OIL PREFORM



JAR PREFORM



P.P PREFORM



PET GLASS & CONTAINERS



PET BOWLS & TRAYS



PET BATHROOM ACCESSORIES



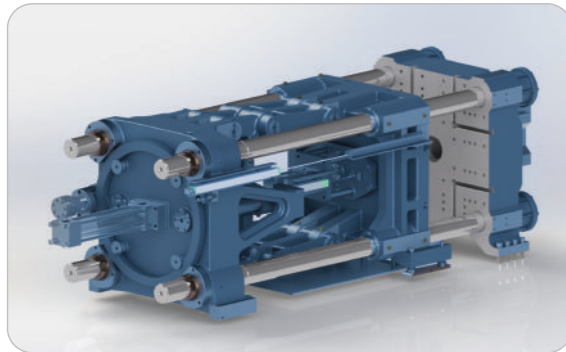

CLAMPING UNIT

- Heavy Duty 5-point Double Toggle Mechanism With Large Mould Opening Stroke.
- High Stiffness Platen Design With Large Mould Mounting Area.
- Platen Casting Design With Finite Element Analysis For Maximum Rigidity.
- Mould Platen With T-slots (140 Ton & Above).
- Long Life By Providing Oil Less Bushing With Graphite Impregnated For Toggle Mechanism.
- Platens With Euromap Standard.
- Long Moving Platen Guide Increases Mould Life.



NUT GEAR

- High Wear Resistant & High Strength Gear Nut (tiebar Nut) That Gives Rigid & Positive Clamping Force.
- Friction Free Easy Moving Mould Height.

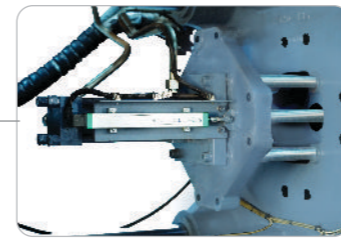

EJECTOR

- Smooth & Fast Ejection.
- Multiple Ejection Point & Evenly Distributed Ejection Force.
- Euromap Ejection Point.
- Easy Accessibility.

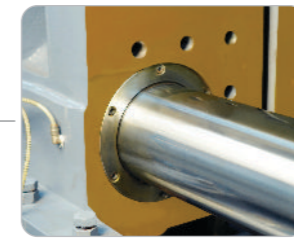

WIPER SEAL

- Keep Lubrication between Platen Hole & Tiebar For Smooth Movement.
- Dust Free Moving Platen Movement Gives Better Tiebar Life



INJECTION UNIT

- High Torque Hydraulic Motor For Better Plasticization.
- Longer Life Of Mould With Dual Nozzle Cylinder Design
- Provision For Multiple Screw Change By Changing Spline Bush Only.
- Low Noise Hydraulic Motor.
- Carriage Loaded Injection to Prevent Material Leakage

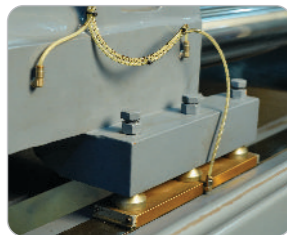

SKATE PAD

- High Wear Resistant Skate-pad For Heavy Mould Loading That Reduces Platen Deflection and Enhances Tiebar Life.
- High Wear Resistant Carbon Steel Strip.

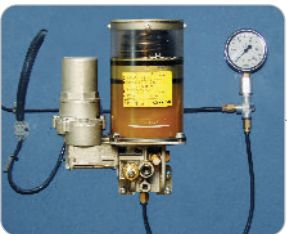

AUTOMATIC GREASE LUBRICATION

- High Pressure Grease Lubrication System Provides Positive Lubrication.
- Ensures Continuous And Optimum Lubrication To Reduce Friction & Longer Toggle Life.

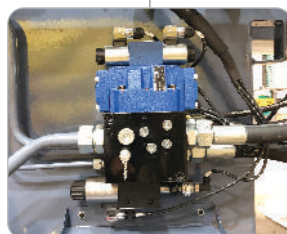

ENERGY EFFICIENT HYDRAULIC

- Return Line Filter With Clogging Sensor.
- High Efficiency & Fast Response Hydraulic Valve With Applicable Pipe Size Selection Reduces Oil Heat & Saves Power.
- Hydraulic Directional Valve With On /off Indicator Connector.

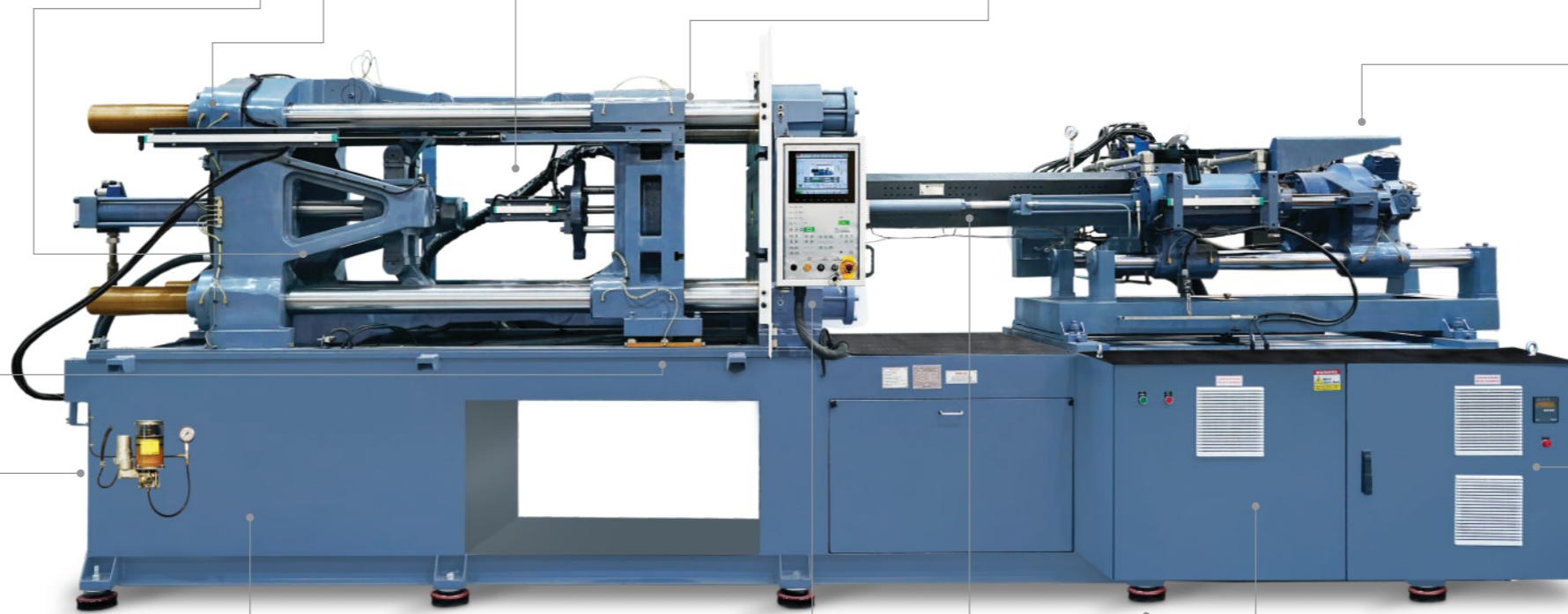

HMI

- 8.0 TFT Colour Display, (10.4 Inch Optional)
- Precise Mould Safety.
- High Speed Microprocessor Controller.
- Self Diagnostics & Fault Finding Capacity.
- Graphical Presentation Of Important Functions.
- Automatic Calibration Of Sensors And Valves.
- PDP & SPC Function.
- Multiple User Passwords.
- Quality Data Logging.
- Unlimited Mould Data Storage Through USB
- USB Connection For Printer, Modem, USB Stick etc.

ANTI VIBRATING PAD

- Minimum Vibrations.
- Precise & Fast Leveling.
- No Civil Foundation Required.



SCREW & BARREL

- Gas Nitrided Injection Screw & Barrel For The Ultimate In Wear Resistance.
- Process Ability At Lower Melting Temperature.
- Excellent Homogeneous Melting.
- Special Screw Design.
- Improved Product Quality.
- Better Plastification Rate.

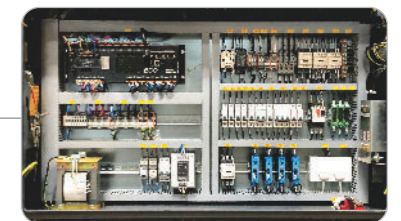

ELECTRICAL PANEL

- High Quality Electrical Components And Excellent Circuit Hardware Design.
- Stable And Reliable Control System With A Stronger Anti-interference Function.
- Ease In Maintenance.
- Over Voltage, Under Voltage Phase Loss And Phase Sequence Protection.
- Separate And Spacious Power & Control Wiring.
- 230 VAC Components Safe By Isolation Transformer.
- Ensured Panel Safety with IP-54 Protection.



INDUCTION MOTOR WITH VARIABLE DISPLACEMENT PUMP

- Outstanding Power Saver.
- Precise And Fast Response.
- Outstanding Consistency And Repeatability.
- Low Noise Level.
- Lower Oil Heat Generation.
- Faster Response Towards Hydraulic System.
- Enhanced Oil & Hydraulic Seal's Life.
- Less Cooling Water Consumption.

PETLINE SERVO Toggle Injection Moulding Machines

Model		080 Ton		100 Ton		140 Ton		170 Ton		200 Ton		280 Ton		360 Ton		480 Ton		600 Ton				
INJECTION UNIT	UNIT	270	270	410	410	590	590	1050	1430	590	1050	1430	1430	1860	2090	1860	2090	3220	2090	3220	3220	4800
INJECTION CAPACITY MAX. (PET)	gm	200	200	289	289	496	496	780	1068	496	780	1068	1068	1415	2080	1415	2080	2925	2080	2925	2925	4515
INJECTION PRESSURE	bar	1800	1800	1904	1904	1585	1585	1476	1491	1585	1476	1491	1491	1436	1236	1436	1236	1339	1236	1339	1339	1940
INJECTION RATE	cc/sec	139	139	131	131	253	253	428	423	253	428	423	423	558	649	558	649	749	649	749	749	674
INJECTION SCREW STROKE	mm	170	170	200	200	220	220	240	280	220	240	280	280	320	360	320	360	400	360	400	400	500
SCREW DIAMETER	mm	36	36	40	40	50	50	60	65	50	60	65	65	70	80	70	80	90	80	90	90	100
SCREW L / D RATIO	-	24	24	24	24	24	24	24	24	24	24	24	24	24	24	24	24	24	24	24	24	24
SCREW SPEED	rpm	280	280	220	220	200	200	175	175	200	175	175	175	145	112	145	112	116	112	116	116	120
NO. OF PYROMETERS (BARREL+NOZZLE)	-	3 +1N	3 +1N	3 +1N	3 +1N	4 +1N	4 +1N	4 +1N	4 +1N	4 +1N	4 +1N	4 +1N	4 +1N	4 +1N	4 +1N	4 +1N	4 +1N	4 +1N	4 +1N	4 +1N	4 +1N	4 +1N
TOTAL HEAT CAPACITY	kw	11.4	11.4	13.5	13.5	17.6	17.6	23.7	29	17.6	23.7	29	29	33.8	42	33.8	42	58	42	58	58	65
CLAMP UNIT																						
CLAMP FORCE	ton	80	100		140			170			200			280			360		480		600	
CLAMP STROKE	mm	300	320		360			430			470			580			680		830		950	
MAXIMUM DAYLIGHT	mm	650	720		830			980			1075			1280			1510		1725		2020	
MINIMUM MOULD HEIGHT	mm	125	150		150			200			200			200			200		300		400	
MAXIMUM MOULD HEIGHT	mm	350	400		470			550			600			700			830		900		1070	
PLATEN SIZE (H x V)	mm	535 x 550	590 x 605		670 x 670			755 x 755			822 x 765			900 x 895			1035 x 1035		1210 x 1180		1350 x 1355	
DISTANCE BETWEEN TIE ROD (H x V)	mm	360 x 360	400 x 400		445 x 445			505 x 505			570 x 500			650 x 600			720 x 680		830 x 770		980 x 880	
EJECTOR STROKE	mm	100	100		120			140			160			160			200		205		225	
EJECTOR FORCE @170 BAR SYS. PRESS.	ton	3.3	5.3		5.3			5.3			7.5			8.5			8.5		10.8		13.3	
MOULD WEIGHT CAPACITY	kg	400	650		1000			1300			1500			2700			4000		5500		7000	
GENERAL																						
SERVO DRIVE	kw	15	15	18	18	22	22	30	30	30	30	37	37	45	50	45	50	55	50	55	55	60
TOTAL OIL TANK CAPACITY	ltr	210	260	260	315	315	400	400	440	440	440	510	510	660	660	660	850	850	850	850	850	950
CONNECTED LOAD	kw	26.5	26.5	31.5	31.5	40	40	54	59	48	54	66	66	79	92	79	92	113	92	113	113	125
MACHINE DIMENSIONS (L x W x H)	m	4 x 1.5 x 2	4.5 x 1.5 x 2	4.5 x 1.5 x 2	5 x 1.6 x 2.1	5.2 x 1.6 x 2.1	5.5 x 1.7 x 2.2	5.8 x 1.7 x 2.2	6 x 1.7 x 2.2	5.9 x 1.9 x 2.3	6.2 x 1.9 x 2.3	6.4 x 1.9 x 2.3	6.5 x 1.9 x 2.4	6.8 x 1.9 x 2.4	7.0 x 1.9 x 2.4	7 x 2.1 x 2.5	7.5 x 2.3 x 2.7	7.8 x 2.3 x 2.7	8.5 x 2.3 x 2.6	9 x 2.3 x 2.6	8.5 x 2.3 x 2.6	9.5 x 2.3 x 2.6
MACHINE WEIGHT (Approx)	ton	3.6	4.2	4.4	5.3	5.8	7	7.2	7.4	7.8	8.1	8.4	12	12.4	12.6	15	15.7	16.2	22.2	23.2	29	30.5

PETLINE VDP Toggle Injection Moulding Machines

Model		080 Ton		100 Ton		140 Ton		170 Ton		200 Ton		280 Ton		360 Ton		480 Ton		600 Ton				
INJECTION UNIT	UNIT	270	270	410	410	590	590	1050	1430	590	1050	1430	1430	1860	2090	1860	2090	3220	2090	3220	3220	4800
INJECTION CAPACITY MAX. (PET)	gm	200	200	289	289	496	496	780	1068	496	780	1068	1068	1415	2080	1415	2080	2925	2080	2925	2925	4515
INJECTION PRESSURE	bar	1800	1800	1904	1904	1585	1585	1476	1491	1585	1476	1491	1491	1436	1236	1436	1236	1339	1236	1339	1339	1940
INJECTION RATE	cc/sec	83	83	120	120	180	180	248	273	180	248	273	273	397	521	397	521	548	521	548	548	456
INJECTION SCREW STROKE	mm	170	170	200	200	220	220	240	280	220	240	280	280	320	360	320	360	400	360	400	400	500
SCREW DIAMETER	mm	36	36	40	40	50	50	60	65	50	60	65	65	70	80	70	80	90	80	90	90	100
SCREW L / D RATIO	-	24	24	24	24	24	24	24	24	24	24	24	24	24	24	24	24	24	24	24	24	24
SCREW SPEED	rpm	215	215	200	200	168	168	162	144	168	162	144	144	155	113	155	113	108	113	108	108	102
NO. OF HEATING ZONES (BARREL+NOZZLE)	-	3 +1N	3 +1N	3 +1N	3 +1N	4 +1N	4 +1N	4 +1N	4 +1N	4 +1N	4 +1N	4 +1N	4 +1N	4 +1N	4 +1N	4 +1N	4 +1N	4 +1N	4 +1N	4 +1N	4 +1N	4 +1N
TOTAL HEAT CAPACITY	kw	11.4	11.4	13.5	13.5	17.6	17.6	23.7	29	17.6	23.7	29	29	33.8	42	33.8	42	58	42	58	58	65
CLAMP UNIT																						
CLAMP FORCE	ton	80	100		140			170			200			280			360		480		600	
CLAMP STROKE	mm	300	320		360			430			470			580			680		830		950	
MAXIMUM DAYLIGHT	mm	650	720		830			980			1075			1280			1510		1725		2020	
MINIMUM MOULD HEIGHT	mm	125	150		150			200			200			200			200		300		400	
MAXIMUM MOULD HEIGHT	mm	350	400		470			550			600			700			830		900		1070	
PLATEN SIZE (H x V)	mm	535 x 550	590 x 605		670 x 670			755 x 755			822 x 765			900 x 895			1035 x 1035		1210 x 1180		1350 x 1355	
DISTANCE BETWEEN TIE ROD (H x V)	mm	360 x 360	400 x 400		445 x 445			505 x 505			570 x 500			650 x 600			720 x 680		830 x 770		980 x 880	
EJECTOR STROKE	mm	100	100		120			140			160			160			200		205		225	
EJECTOR FORCE @170 BAR SYS. PRESS.	ton	3.3	5.3		5.3			5.3			7.5			8.5			8.5		10.8		13.3	
MOULD WEIGHT CAPACITY	kg	400	650		1000			1300			1500			2700			4000		5500		7000	
GENERAL																						
ELECTRIC MOTOR	kw	11.2	11.2	15	15	18.7	18.7	22.5	30	18.7	22.5	37	30	45	50	45	50	55	50	52.5	55.5	60
TOTAL OIL TANK CAPACITY	ltr	210	260	260	315	315	400	400	440	440	440	510	510	660	660	660	850	850	850	850	850	950
CONNECTED LOAD	kw	23	23	28.5	28.5	36.5	36.5	46.5	59	36.5	46.5	59	59	79	92	79	92	113	92	110.5	113.5	125
MACHINE DIMENSIONS (L x W x H)	m	4 x 1.5 x 2	4.5 x 1.5 x 2	4.5 x 1.5 x 2	5 x 1.6 x 2.1	5.2 x 1.6 x 2.1	5.5 x 1.7 x 2.2	5.8 x 1.7 x 2.2	6 x 1.7 x 2.2	5.9 x 1.9 x 2.3	6.2 x 1.9 x 2.3	6.4 x 1.9 x 2.3	6.5 x 1.9 x 2.4	6.8 x 1.9 x 2.4	7.0 x 1.9 x 2.4	7 x 2.1 x 2.5	7.5 x 2.3 x 2.7	7.8 x 2.3 x 2.7	8.5 x 2.3 x 2.6	9 x 2.3 x 2.6	8.5 x 2.3 x 2.6	9.5 x 2.3 x 2.6
MACHINE WEIGHT (Approx)	ton	3.6	4.2	4.4	5.3	5.8	7	7.2	7.4	7.8	8.1	8.4	12	12.4	12.6	15	15.7	16.2	22.2	23.2	29	30.5

• Injection unit change is possible as per requirements.
• Actual figures may change depending on your final machine configuration.

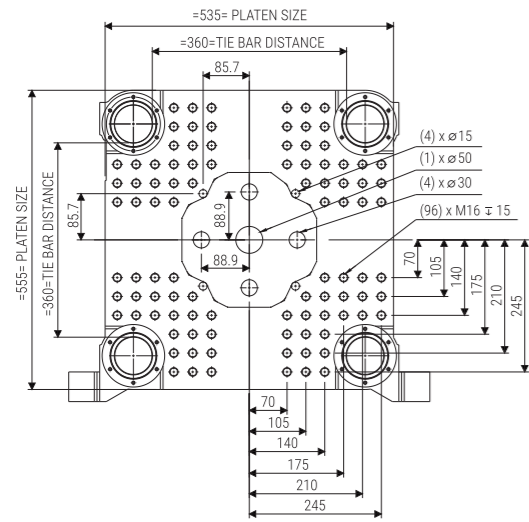

80 Ton Moving Plate

Stationary Platen : Locating Ring Ø125 (±0.10 TO ±0.20)

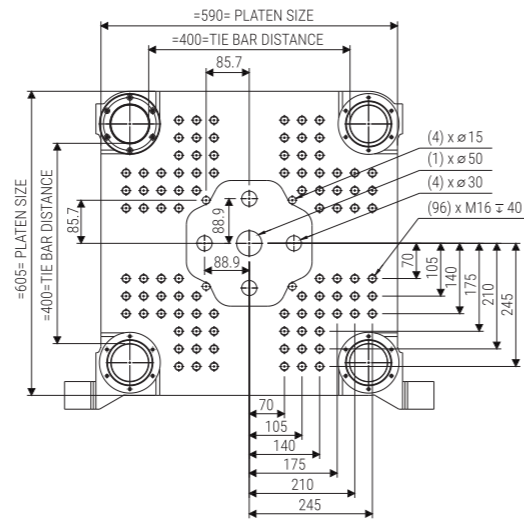

100 Ton Moving Plate

Stationary Platen : Locating Ring Ø125 (±0.10 TO ±0.20)

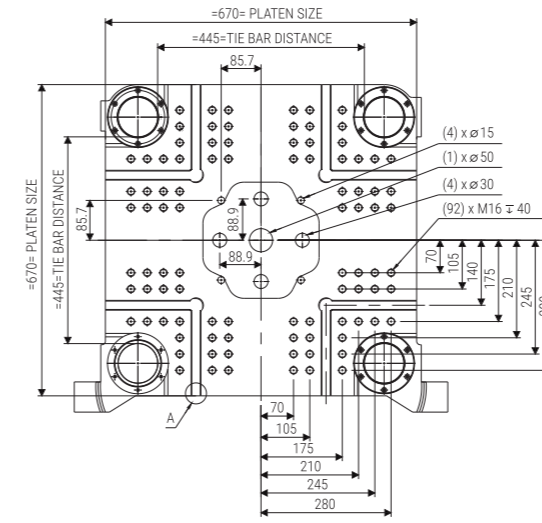

140 Ton Moving Plate

Stationary Platen : Locating Ring Ø125 (±0.10 TO ±0.20)

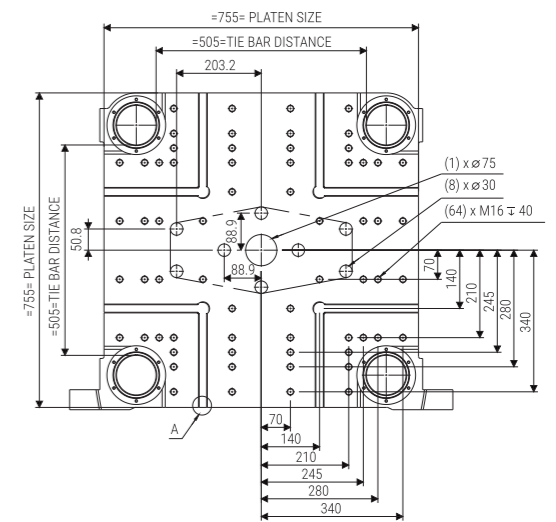

170 Ton Moving Plate

Stationary Platen : Locating Ring Ø125 (±0.10 TO ±0.20)

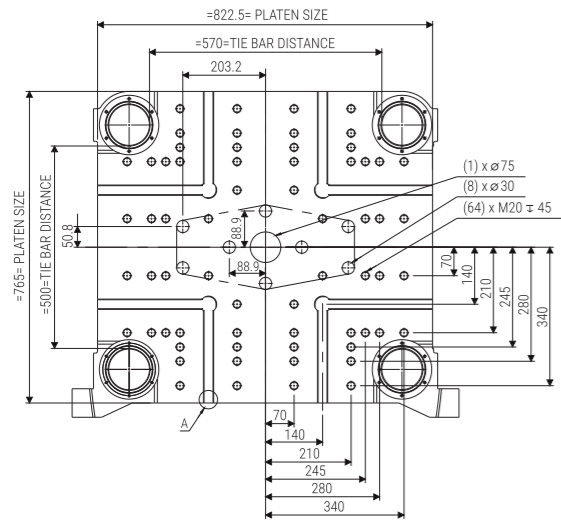

200 Ton Moving Plate

Stationary Platen : Locating Ring Ø160 (±0.10 TO ±0.20)

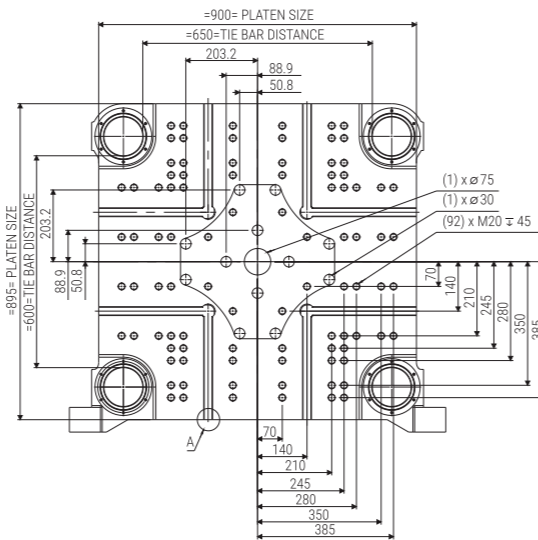

280 Ton Moving Plate

Stationary Platen : Locating Ring Ø160 (±0.10 TO ±0.20)

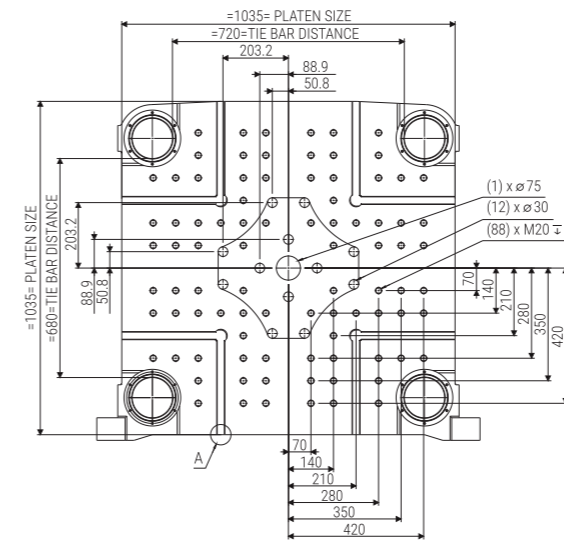

360 Ton Moving Plate

Stationary Platen : Locating Ring Ø160 (±0.10 TO ±0.20)

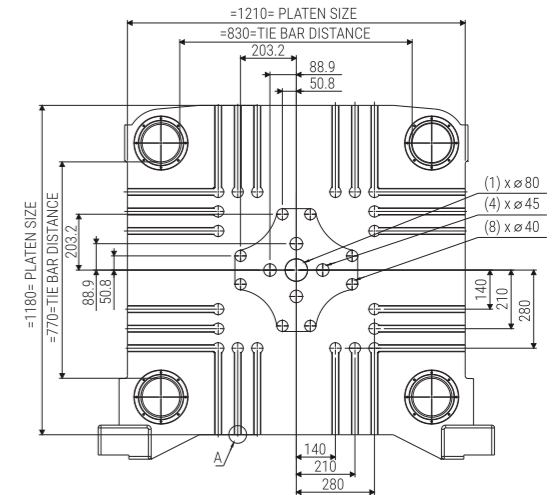

480 Ton Moving Plate

Stationary Platen : Locating Ring Ø200 (±0.10 TO ±0.20)

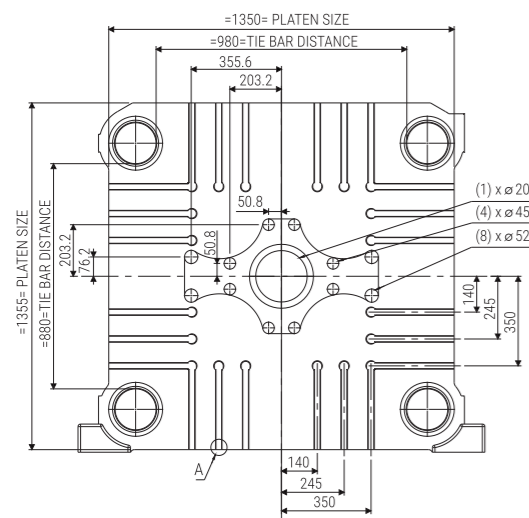

600 Ton Moving Plate

Stationary Platen : Locating Ring Ø250 (±0.10 TO ±0.20)

T-SLOT DETAIL OF STATIONARY PLATEN & MOVING PLATEN

MACHINE	T-SOLT			
	A	B	C	D
80 TON	-	-	-	-
100 TON	-	-	-	-
140 TON	18	32	14	36
170 TON	18	32	14	36
200 TON	22	40	18	45
280 TON	22	40	18	45
360 TON	22	40	18	45
480 TON	22	40	18	45
600 TON	22	40	18	45

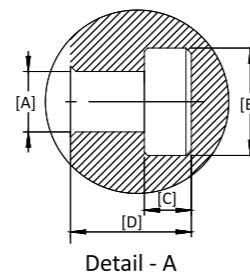

NOTE : ALL DIMENSIONS ARE IN MM.
T-SLOT & THREAD DIMENSIONS ARE AS PER EURO MAP STANDARD.
EJECT. CENTER DIST. ARE TYPICAL IN FOUR QUADRANTS

PLASTIC MATERIALS CHARACTERISTICS

MATERIAL	DENSITY gm/cc	PROCESSING TEMPERATURE (C°)	CLARITY T/O/C	kg/cm2 TENSILE STRENGTH AT YEILD	ELONGATION AT BREAK %	SOFTENING TEMPRATURE VICAT 0° C	HEAT DEFLECTION 0° C AT 66 PSI
LDPE	0.92	160-210	Translucent	95	200	85	50
LLDPE	0.92	180-260	Translucent	100	100	80	45
HDPE	0.96	190-280	T-O	250	500	126	75
PP Copolymer	0.90	190-300	T-C	290	500	150	90
PP Homopolymer	0.90	190-300	Translucent	310	200	152	96
PS (GPPS)	1.05	180-220	Clear	420	5	102	85
HIPS	1.05	180-220	T-O	275	45	88	83
ABS	1.05	210-270	Opaque	440	20	95	86
SAN	1.04	220-270	Clear	650	4	107	95
Polycarbonate (PC)	1.2	260-310	Clear	680	150	150	144
Nylon-6	1.13	240-270	T-O	740	40	215	165
Nylon-66	1.13	270-300	T-O	1240	300	245	238
RPVC	1.45	150-210	Clear	440	20	-	76
Acrylics	1.19	200-260	Clear	700	3	89	90
PBT	1.31	220-260	Opaque	530	300	172	155
Polyurethane	1.20	185-240	Clear	520	510	116	-
Acetal	1.41	180-240	Opaque	700	55	-	172
TPE	1.2	180-240	Opaque	310	375	195	111
PET	1.38	260-310	Clear	880	70	110	85

CLAMPING UNIT

Heavy duty 5-point double toggle mechanism with large mould opening stroke.
High stiffness platen design with large mould mounting area.
High wear resistance & high strength gear nut (tiebar nut) gives rigid & positive clamping force.
Five stage mould close / open speed (slow-fast-slow) & pressure.
Multi stage digital speed and pressure setting to operate the mould.
Computer aided design toggle mechanism gives optimal mould closing and opening speed profits.
Ramping adjustment for accurate position.
Linear transducer for accurate clamp position.
Mould protection with repeat again option.
Travel time display for close & open for producing any item while operations.
Auto-mould height adjustment with hydraulic motor.
Hard-chrome plated high-tensile steel tie-bars with stress relieve design.
Auto-lubrication based on shot adjustment (as standard features).
Hydraulic ejector with multiple selection. (continuous, shake, hold etc.)
Linear transducer on ejector cylinder.
Shaking ejector for multi-cavity mould.
Less vibrations & jerks due to ramp adjustment.
Large mould mounting area for producing large articles especially useful for pet preform, pipe fittings etc.
Platen casting design with finite element analysis for maximum rigidity.
Mould platen with t-slots (140 Tons & above).
Hydraulic & electrical safety interlocks during moving platen movements for moulds & operator safety.
Separate pressure & speed setting for mould set-up.
All casting passed through strict ultrasonic test and tensile testing process.
High wear resistant skate-pad for heavy mould loading.
Long life by providing oil less bushing, with graphite impregnated for toggle mechanism.
Transparent vision on both safety doors.
Trouble free precise clamping force for long period through heavy-duty toggle design.
Extra life to toggle mechanism with top fixed cover which keeps clamping unit dust free.
Mould Clamp & Fasteners

HYDRAULIC SYSTEM

Digital oil temperature gauge.
Oil level gauge (low & high).
Direct reading hydraulic pressure.
Contamination free oil tank with Air breather.
Compact, easily accessible injection and clamping valves to minimize the heat generation.
Return line filter as standard accessories.
Alarm / shut down for return filter clogging.
Alarm / shut down for low oil level. (hydraulic tank)
Alarm / shut down for low lubrication oil level.
Provides high safety as main motor shuts down on opening rear gate.
Hydraulic directional valve on/off indicator connector.
Inline 10 Micron Filtration unit for Oil Filling Port.

CONTROL SYSTEM

Voltage meter.
Multi password facility for operators.
M.C.C.B. Operating Mechanism.
SMPS - Switched Mode Power Supply gives Linear power supply.
Star delta motor starter for (N 100 & above).
Digital setting timers.
M.C.B. for each heating zone.
PID temp controller for accurate control.
Dedicated microprocessor control system with led input / output indicator for simplified checking
Digital display timer.
Digital display shot counter.
MPCB for motor protection.
Pressure & flow for each function control by Microprocessor.
Linear scale for injection, clamping & ejector cylinder.
Value change record page.
Alarm history page.
Printer interface with USB port.
Production / hour in vertical-bar for year.
In case of short circuit I/O replaceable on board.
Easy export / import of mould & machine data.
Hold button for on screen help (related to controller).
Injection cool prevent time stable.
Panel cabinet high temperature shut-down.
Power ON time.
Extra electric power supply socket for single phase & three phase.
Hourly energy consumption statics page (Product cost calculator)
Remote diagnosis by connecting with local PC via Ethernet port for any no. of machine.

Power Consumption

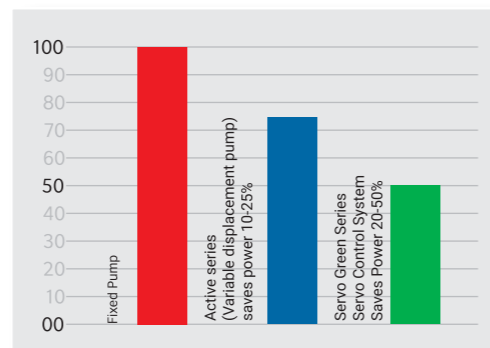

Note : Power Consumption is dependent on products (Articles).

SAFETY FEATURES IN RESPECT OF ALL MODELS.

Hydraulic safety on both front & rear door. | Electric mould safety.
Magnetic grills in hopper. | Provision for M.C.C.B.
Over load circuit breaker. | Under voltage-over voltage protection.
Reverse phase, single phase protection.
Providing hooks of commensurate size for risk free lifting of machine.

INJECTION UNIT

Gas nitrided hardened screw and barrel, for wear resistance and long life.
barrier 24 L/D Ratio Screw for homogeneous plasticizing with maddock design.
Digital back pressure for accurate refiling.
High torque hydraulic motor for better plasticization.
5-stage injection speed pressure & position control.
3-stage injection holding speed pressure & position control.
Hopper sliding arrangement for material removal.
Electric shot counter.
Cold slug Ejection by time.
Intrusion moulding program.
Selection of injection time & position both.
Screw tachometer (Digital RPM).
Pre-suck back function and after plasticizing suck back.
Heater failure & thermocouple failure detector.
High / low temperature alarm. (suitable low-high limit)
Auto heat start-up.
Longer life of mould with Twin Cylinder Design & Dual nozzle centering alignment device.
Linear potentiometer for injection / plasticizing.
Auto purging facility.
Ceramic bands heaters for instant heating.
Barrel heater safety cover.
Nozzle contact force confirmation with use of pressure switch.
Temperature Sensor at feed throat to ensure continuous production.
S.S. Water Manifold.



SERVO HYDRAULIC SYSTEM

- Powerpack with Servo Control
- Precise & Fast Control through direct Servo Motor
- Outstanding Power saver (20-50% Compared to Fixed pump)
- Low Oil Heat generation
- Faster response towards Hydraulic system
- Optimised Vibration & noise through C.G. balanced mounting & antivibration pads
- Less Cooling water consumption
- Outstanding Consistency & repeatability

• Photography may show attachments or accessories, which may not be part of the standard scope of supply.
• Due to continuous improvements with up-gradation of technology specification & components are subject to change without notice.

OPTIONAL FEATURES

Bi-metallic screw barrel.
Hopper dryer & Hopper loader.
Hydraulic core-pulling and unscrewing.
Running hour-meter.
Auto-taker (robot) interface.
Air-ejector.
Hydraulic oil.
Gas injection interface only up to digital output from control.
Blowers with heaters for processing heat sensitive materials.
Nozzle shut off provision.
Hot runner temperature controller.
Extended nozzle with heater.
Multiline water battery with temperature Indicator guard.
Close loop valve.
Ladder for loading material in hopper.
Ejector in back position confirmation by proximity sensor.
Remote monitoring .

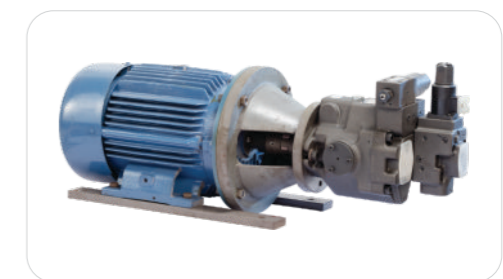

INDUCTION MOTOR AND PUMP DRIVE

- Powerpack with Variable Displacement pump
- Precise & Fast Control through pump PQ block
- Outstanding Power saver (10-25% Compared to Fixed pump)
- Low Oil Heat generation
- Faster response towards Hydraulic system
- Optimised Vibration & noise through C.G. balanced mounting & antivibration pads
- Less Cooling water consumption
- Outstanding Consistency & repeatability